

M12x1.75 THREAD x 1.00 DEEP
C'BORE DIA. .492 x .236 DEEP

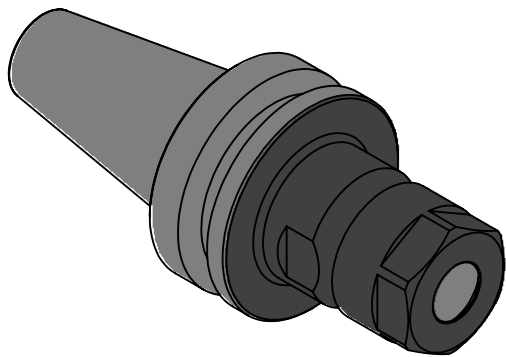
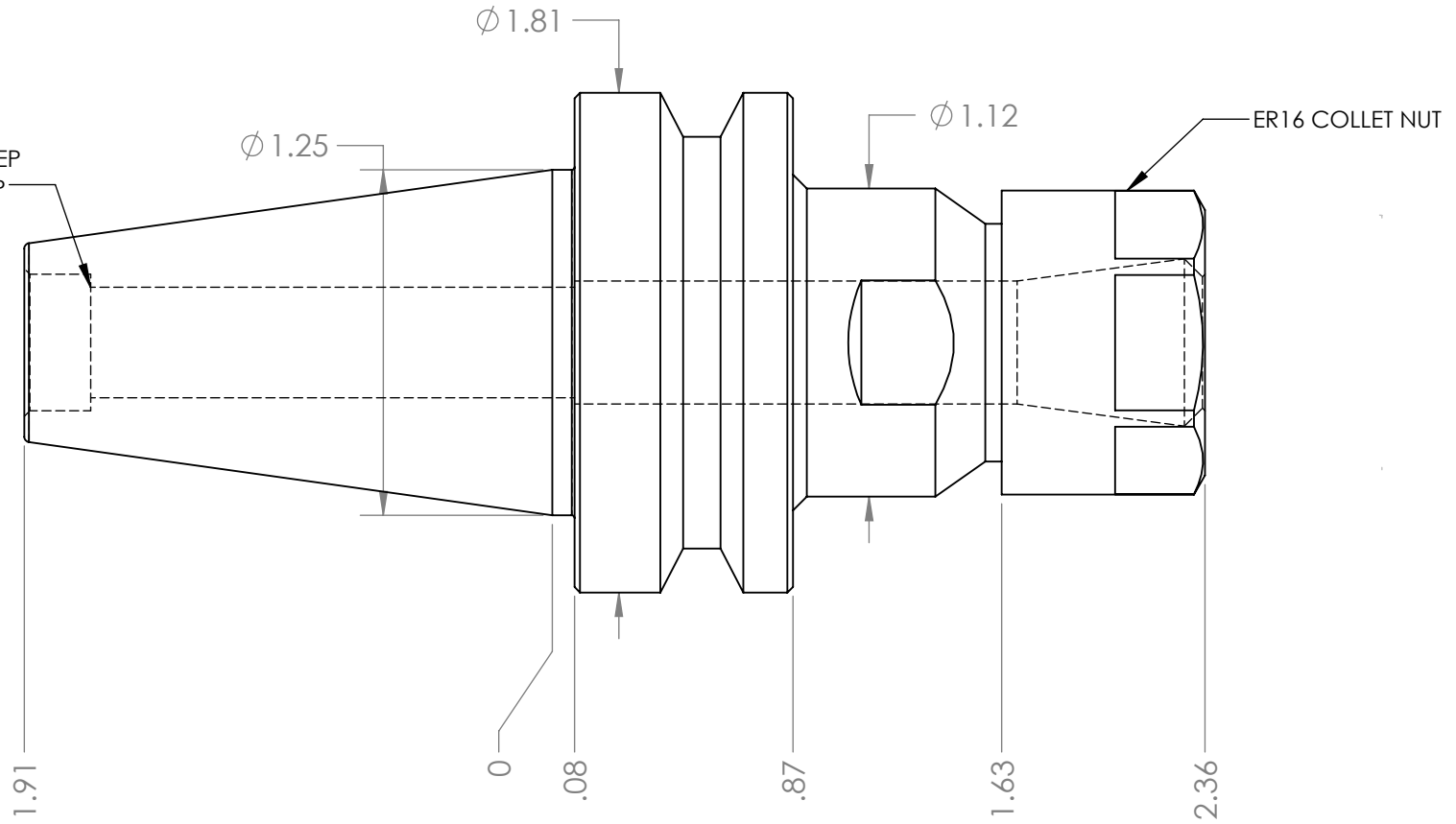

NOTES:

WORKS ON ALL BT30 MACHINES

TAKES ALL ER16 COLLETS FROM .020"-.4375"

USES WRENCH PART # ER16 WRENCH (NOT INCLUDED)

FOR MORE PRODUCT DETAILS PLEASE GO TO MARITOO.COM
AND SEARCH ITEM # LISTED ON THIS PRINT

MARITOO

WWW.MARITOO.COM

ITEM#

BT30 ER16-60-WF

Made in USA